

## Silicon TV tuners kick the CAN

Gregory A. Quirk and Mark Roberts  
EETimes Design News - June 17, 2008

under the **hood**

As digital TV starts to deploy, there have been several announcements recently for silicon TV tuners that focus on terrestrial broadcast and cable set-top box applications, rather than on the more ethereal mobile TV that has been touted as the next killer application for handheld devices.

As opposed to the formative on-again, off-again mobile TV promise, digital TV is a real market available now that IDC has projected to grow at a compound annual growth rate of close to 24 percent, with unit volume measured in hundreds of millions per year.

Two camps have developed vis-à-vis silicon tuner ICs: one preferring low-power, mobile-oriented tuners that are usable in all applications, and one seeking solutions aimed solely at fixed-TV applications (which can benefit from additional power budget).

The majority of semiconductor development has recently focused on the mobile TV application. Traditionally, fixed-TV silicon tuners have focused on solutions for cable set-top boxes, but a few vendors have tried to address the needs of multiband hybrid analog/digital tuners for the higher-growth digital TV market: notably, MaxLinear, Microtune and XCeive.

After the onerous power constraints of a truly mobile application are removed, there are a couple of areas where the performance of a silicon tuner can be improved:

- Faster channel acquisition;
- Better filtering (adjacent channel rejection).

Of course, silicon tuners already have inherent advantages over traditional shielded discrete tuner implementations (CAN tuners):

- Lower power;
- Flexibility for addressing the global market with a single solution;
- Consistent performance and quality (tighter production tolerances);
- Lower manufacturing cost at all phases of production;
- A smaller form factor;
- Easy implementation for multiple tuners for picture-in-picture (PIP), multichannel visual programming guides and PVR applications.

Until the most recent product announcements, silicon tuners

have fallen well short of the performance offered by hand-tuned CAN tuners. But one company in particular seems to have focused on achieving the best possible silicon solutions for fixed TV tuners: XCeive Inc.

XCeive has addressed all the opportunities above and is now selling its fourth-generation TV tuner product: the XC5000. The tuner is claimed to exceed the performance of traditional CAN tuners from companies such as Philips, Samsung, Thomson and Panasonic, blowing away other silicon tuners.

XCeive claims better performance in both digital sensitivity (greater than a 2-dBm improvement) and analog performance (a 2- to 5-dB improvement in SNR) over premium CAN tuners.

The XCeive tuners all feature low bill-of-materials costs and have successfully eliminated three 20-cent SAW filters and a 50-cent analog demodulator seen in other designs, reducing the total cost by more than a dollar. The XC5000 achieves 5-millisecond channel detection, making it possible to channel-surf again (a feature sadly lacking from many set-top boxes today). The faster acquisition time also contributes to a better user experience when doing a channel scan setup and makes possible a virtual tuner mode that can quickly sample a number of channels for a visual programming guide.

Semiconductor Insights Inc. recently completed a report on the XC5000 titled "Functional Layout II of the XCeive Corp. XC5000ACQ TV Tuner." This report, and some earlier work done on the XC3028--namely, "Quick Look IV of the XCeive Corp. XC3028 RF to Baseband Receiver"--allow the quick examination of how XCeive's tuners have evolved over three generations of silicon, making it evident how they have reached the levels of performance they now boast.

The XC3028 was previously discussed in an Under the Hood article, "Silicon TV tuners clearing hurdles." This product was a worldwide hybrid tuner aimed at PC TV and "value" TV applications, with specifications suitable for up to 64 QAM. It was characterized as "almost" as good as a CAN tuner, which fit well

**Silicon TV tuners kick the CAN** (continued)

EETimes Design News - June 17, 2008

Xceive block diagram is functionally identical to that of the XC3028.

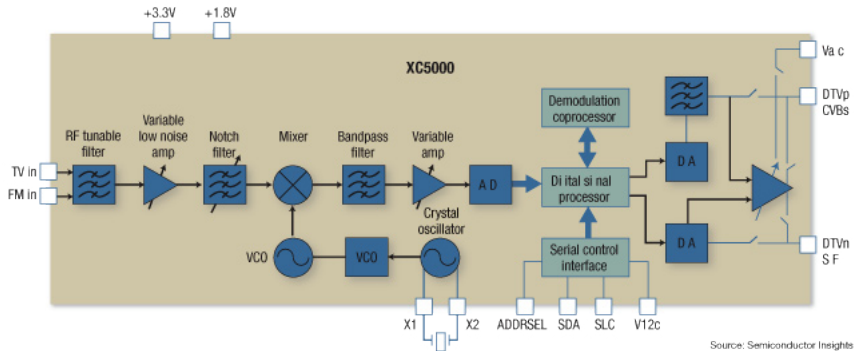

Source: Semiconductor Insights

with its target markets. The XC3028 was fabricated in a 0.35- $\mu\text{m}$  SiGe BiCMOS process; the foundry most likely was Jazz Semiconductor.

A comparison of the two parts makes it immediately evident that the XC5000 die size is almost identical to the earlier XC3028; yet the process node was determined to be 0.18  $\mu\text{m}$  instead of the 0.35  $\mu\text{m}$  of the earlier-generation part. The XC5000 was 19 mm<sup>2</sup> (4.7 mm x 4.1 mm), whereas the XC3028 measured 18 mm<sup>2</sup> (4.3 mm x 4.2 mm). Xceive states that the XC5000 is fabricated in a 0.18- $\mu\text{m}$  SiGe BiCMOS process from Jazz Semiconductor.

When contrasted with the XC3028, however, the XC5000 delivers major differences in key specifications that help it achieve the breakthroughs necessary to exceed the performance of premium CAN tuners and support up to 256 QAM in digital TV applications.

The changes include a 1-dB improvement in noise figure (6 dB vs. 5 dB); a 10-dBc/Hz improvement in phase noise (-85 dBc/Hz); a 5-dB boost in image rejection (65 dB); a 10-dB-greater AGC range (90 dB vs. 80 dB); and better video SNR (unweighted), of 54 dB vs. 48 dB in the XC3028.

Because the major analog passive components (inductors and capacitors) do not scale well, as demonstrated by the die photos, we can surmise that a major benefit was gained from the 0.18- $\mu\text{m}$  process because of the large increase in logic gate density that could be applied to DSP functionality. In fact, Xceive indicated that much of the improvement in the performance was made possible by enhanced “near ideal” DSP filters, developed in-house as part of its proprietary IP.

Major portions of the analog circuitry look to have been completely duplicated between the two devices: in particular, the RF tunable filters, LNA and notch filtering, as well as the capacitor

bank used for low-pass filtering. Because the published block diagrams of the two parts are almost identical, we can look for differences in the analog circuitry to find potential areas that have been improved.

There are two significant changes in the analog circuitry: a new area with a large single-ended inductor and a couple of additional differential inductors in the VCO (the lower right corner of the XC5000 die).

The new single-ended inductor, placed adjacent to the Filter/LNA block, could account for the wider AGC range, with the inductor part of an additional AGC stage.

The change in the VCO, the two differential inductors possibly resulting in two bands of tuning, probably accounts for the improvements in noise figure and phase noise.

Last, we are left with a 5-dB improvement in image rejection and a 6-dB video SNR gain. These could be caused by the application of the roughly 75 percent increase in logic gates made possible by the process shrink, although the improved phase noise may contribute to the video SNR as well.

Although the Xceive XC5000 uses a larger die than some of its peers, we have clearly seen how the silicon area has been put to good use in addressing the high-end TV tuner market with a part that ultimately delivers better performance in a smaller footprint, with overall lower costs, than traditional technologies, especially when the loaded cost to manufacture is taken into account.

*Gregory A. Quirk (gquirk@techinsights.com) is product manager at TechOnline, a division of TechInsights.*

*Mark Roberts was formerly principal analyst for wireless/RF at TechOnline unit Semiconductor Insights (Katana, Ontario).*